

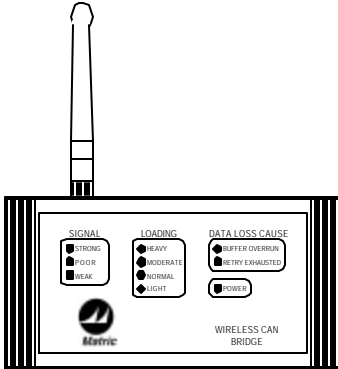

Wireless CAN Bridge CB-300

DESCRIPTION:



The Controller Area Network (CAN) has gone wireless! Escape the limitations of hard wired systems using Matric's Wireless CAN Bridge. The Wireless CAN Bridge is ideal for any distributed application where wiring is easily damaged, or where freedom of motion is critical.

The Wireless CAN Bridge functions as a wireless link that transfers CAN messages. Using the Wireless CAN Bridge, nodes on either side of a wireless link can communicate at a typical separation of 500 feet. A full 64 node DeviceNet* can be implemented depending on scan rates and frame density. Since actual CAN messages are transferred, the Wireless CAN Bridge supports any type of CAN bus standard including CAN Open and CAN Kingdom.

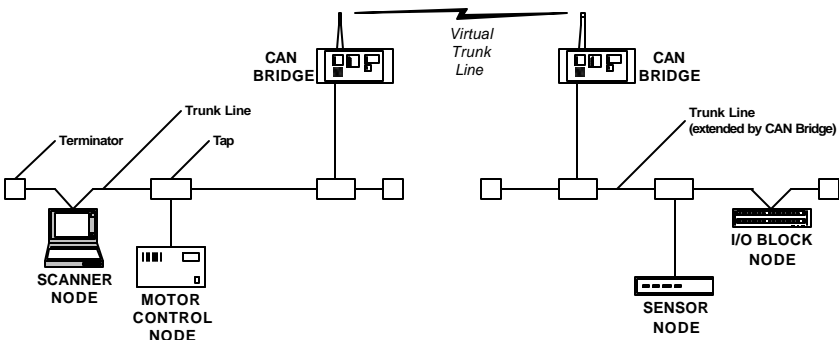

SPECIFICATIONS:

Functional

- 1200 frames per second transfer rate (max)
- Supports any CAN Bus or DeviceNet* (Bosch CAN 2.0b)
- Five pin male micro connector
- 16 bit CPU
- CPU watchdog

Radio

- Typical range of 500 feet
- 2.4 – 2.4835 GHz with 16 channels
- DSSS DBPSK modulation
- Output power, +10 dBm (10mW)
- Single heterodyne conversion
- Remote antenna mount to 30 feet
- Radio complies with FCC Part 15B, no user license required

Configuration Options

- Configuration via internal dip switches
- Radio link master or slave
- Hi/low RF power
- Standard versus extended CAN frame formats
- Host Interface baud rate (125K, 250K, 500K)
- Channel (1-16)
- Mode (Data security and throughput options)

Power Source

- 7-30VDC, 200 mA at 24VDC +/- 5%

Status Indicators

- Signal strength
- Bus loading
- Data Loss Cause
- Power

Physical

- Size: 3 1/8 X 3 X 6 5/16 Inches
- Weight: 1 Lb
- DIN rail or panel mount
- Sealed enclosure
- Operational temperature 0°C to 70°C
- Storage temperature -40°C to 85°C

APPLICATION:

The Wireless CAN Bridge provides a frame transfer rate of 1200 CAN frames per second (fps) which is roughly equivalent to a fully loaded 125k baud system. The effectiveness of the CAN Bridge in any particular application depends on network loading (including bursts). The loading on a CAN based network is effected by a number of factors including: polling rate of the network scanner, node count, and change-of-state activity. According to ODVA, 30% loading is recommended for DeviceNet systems employing change-of-state devices and 80% loading is recommended for polled DeviceNet systems. Heavily loaded systems increase the probability that CAN messages will be discarded due to RF bandwidth limitations.

The transfer rate of 1200 fps is based on a typical scenario of 500 feet separation without significant RF obstacles. The actual transfer rate in any application is dependent upon the quality of the RF link. Structural components such as steel walls or decking, earth tunnels, and metal equipment can effect the quality of the RF link. Also, radiation sources such as other radio systems, high power switching, and magnetic fields can effect the quality of the RF link. A site assessment should be performed at any site where a new RF control is to be installed.

The Wireless CAN Bridge provides a point-to-point data transfer in order to achieve the required throughput over the wireless link. A system requiring multiple wireless links can accomplish this using multiple pairs of the Wireless CAN Bridge. Up to three CAN Bridge pairs can be operated in close proximity in most situations. To operate in close proximity, use channels with the widest possible separation (channels 0, 7, and 14). System integrators must be aware of potential Near / Far problems and the complexity related to operating DSSS radios in such installations. Also, the number of radio pairs that can be operated in proximity is dependent upon the actual distances between radios. Refer to the installation section for details regarding radio issues, site assessment, and optimal antenna placement.

The rate at which CAN frames are received and transmitted by the Wireless CAN Bridge falls within the timing constraints of Bosch CAN Standard 2.0b. While meeting network requirements for data link and higher levels of communication, the time required for retransmission may still have an effect on the overall timing of a control system.

CONFIGURATION:

Configuration of the Wireless CAN Bridge is accomplished by manually setting switches inside its enclosure. The CAN Bridge enclosure lid must be removed to access the configuration switches. Users may only perform the configuration described in this manual. Changing other switch or trimmer settings may invalidate agency approvals.

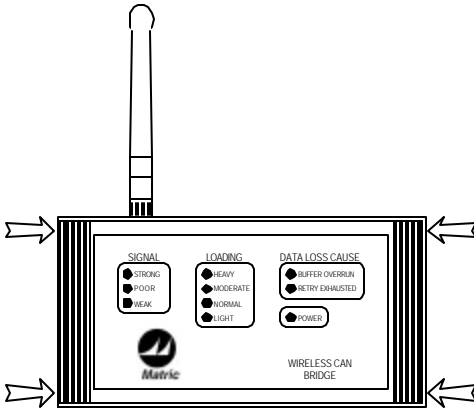

To access configuration switches, first, use a flat screwdriver to pry off the two decorative covers at the right and left ends of the lid. Four pry slots are provided as shown below. Then unscrew the four screws that attach the lid to the chassis of the Wireless CAN Bridge using a philips or a flat screwdriver.

The Wireless CAN Bridge has 12 configuration switches arranged in 3 banks S1, S2, and S3. Each bank, contains 4 switches. These switches allow the user to easily customize the Wireless CAN Bridge to fit the desired application.

IMPORTANT: Employ ESD precautions to avoid static discharge when touching the CAN Bridge circuit board. ESD can cause damage leading to catastrophic or intermittent product failure modes.

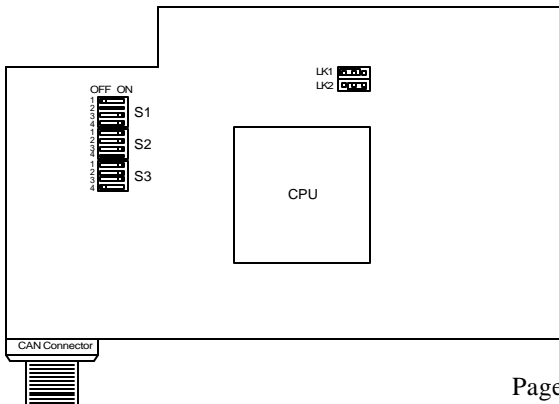

The following paragraphs describe each switch setting in more detail. The format Sb – s, where b is the bank number and s is the switch number within that bank, will be used. The “as shipped” settings are shown with an asterisk “*”.

The CB-300 must be reset (power cycled) before switch settings take effect.

Switch S1-1

Selects Node Communication Type for internal radios. A Radio System must consist of only one master and only one slave per channel. The master is the initiator of the master/slave pair. Before the radios link, the slave will only listen for a master and the master will transmit to find a slave. See switches S2 – 1,2,3,4 for channel settings.

Node Type	(S1-1)
SLAVE*	ON*
MASTER	OFF

Switches S1-2,3,4

Selects the number of retries. The radio will retransmit an unsuccessful packet the selected number of times before discarding the packet. Increasing retries may slow the communication process, but may help reduce discarded packets. CAN Bridge units built after 11/02 have been modified to allow more retries.

Retries Before 11/02	Retries After 11/02	(S1-2)	(S1-3)	(S1-4)
1	1	ON	ON	ON
2*	2*	ON*	ON*	OFF*
3	4	ON	OFF	ON
4	8	ON	OFF	OFF
5	16	OFF	ON	ON
6	32	OFF	ON	OFF
7	64	OFF	OFF	ON
8	128	OFF	OFF	OFF

Switches S2-1,2,3,4 Selects the operating channel. A master/slave pair must be set to the same channel to operate. See switch S1 – 1 for selecting master/slave operation. To operate multiple pairs of CAN Bridge in close proximity, the radios must be configured to the widest possible frequency separation.

Channel	(S2-1)	(S2-2)	(S2-3)	(S2-4)	Freq (GHz)
0*	ON*	ON*	ON*	ON*	2.412**
1	ON	ON	ON	OFF	2.412**
2	ON	ON	OFF	ON	2.417
3	ON	ON	OFF	OFF	2.422
4	ON	OFF	ON	ON	2.427
5	ON	OFF	ON	OFF	2.432
6	ON	OFF	OFF	ON	2.437
7	ON	OFF	OFF	OFF	2.442
8	OFF	ON	ON	ON	2.447
9	OFF	ON	ON	OFF	2.452
10	OFF	ON	OFF	ON	2.457
11	OFF	ON	OFF	OFF	2.462
12	OFF	OFF	ON	ON	2.467
13	OFF	OFF	ON	OFF	2.472
14	OFF	OFF	OFF	ON	2.484
15	OFF	OFF	OFF	OFF	2.412**

**Duplicate channel frequencies

Switches S3-1, 2

Selects the CAN Bit Rate.

Bit Rate (Bits/Sec.)	(S3-1)	(S3-2)
125K*	ON*	ON*
250K	ON	OFF
500K	OFF	ON
125K	OFF	OFF

Switch S3-3

Selects Standard or Extended CAN framing. DeviceNet* uses standard framing. Some varieties of CAN may use extended framing.

CAN Type	(S3-3)
11 bit (Standard CAN) *	ON*
29 bit (Extended CAN)	OFF

Switch S3-4

Enables RF High Output Power. It is recommended to operate the radios at the lowest possible power setting to reduce reflected signals.

High RF Power	(S3-4)
Enabled	ON
Disabled*	OFF*

INDICATORS:

The Wireless CAN Bridge provides three separate groups of diagnostic LED indicators. The groups are labeled “Signal”, “Loading”, and “Data Loss Cause.” In addition to these groups, a power indication LED is also provided.

Signal Indicators

The signal indicators provide information about the integrity and robustness of the RF Signal. The three levels may be described as a function of data throughput.

Strong	Indicates the best data throughput. Data packets are being transferred to the radio at a rate equivalent to between 100% and 110% of full CAN trunk line loading (at 125k baud).
Poor	Reduced data throughput. Data packets are being transferred at a rate between 50% and 100% loading at 125k baud.
Weak	Radios are linked, but data throughput is low. Data packets are being transferred at a rate between 0% to 50% loading.
No Indicators	Data rate is zero. No RF link established.

Data Loss Cause

The data loss cause indicators provide information about packets that are discarded due to throughput constraints. Two indications are provided, Buffer Overrun and Retry Exhausted. Scanner retries must be set at a level that mitigates data loss at the system level.

Buffer Overrun	CAN packets entering the transmit buffer have overrun the RF link capacity. One or more CAN messages are discarded.
Retry Exhausted	The configured number of RF transmit retries has been exceeded. One or more RF packets are discarded. Note: RF data packets may contain up to 2 CAN messages.
No Indicators	No data loss.

Loading Indicators

The loading indicators show the number of CAN packets that are being written to the RF transmit buffer. The four levels may be described as a function of RF bandwidth usage by CAN packets. Note: Buffer overruns may effect this indicator due to discarded CAN packets.

Heavy	50 % - 100 % of the available bandwidth is being utilized for CAN messages.
Moderate	35 % - <50 % of the available bandwidth is being utilized for CAN messages.
Normal	10 % - <35 % of the available bandwidth is being utilized for CAN messages.
Light	0+ % - <10 % of the available bandwidth is being utilized for CAN messages.
No Indicators	No CAN messages transferred.

Power Indicator

The power indicator implies the presence of electrical power. It is a hardwired LED that does not indicate the quality of the power detected.

Power LED On	DC Power is On.
No Illumination	DC Power is Off.

Internal Indicators

There are several internal LEDs that may be useful for diagnostic purposes. D4 indicates power to the microprocessor board. D8 indicates radio message receive activity. D6 indicates radio message transmit activity. The LED on the radio board also indicates radio message transmit activity.

INSTALLATION:

The Wireless CAN Bridge can be bolted directly to a control panel, or mounted to a DIN rail. Remove the two decorative covers at the right and left ends of the lid to access the mounting holes for direct panel mount (or to attach the DIN rail clips). See the Configuration section for instruction on removing the decorative covers.

CAUTION: Many types of threadlock will weaken the plastic enclosure of the CAN Bridge. Instead, use lock washers, or a threadlock that will not damage plastic (such as Premabond MM115) to secure mounting screws. Also, do not over-torque panel mounting screws. Use washers as needed to protect the enclosure and provide a solid base for tightening mounting screws.

A DIN rail mounting kit is available for attaching the Wireless CAN Bridge to either EN 50-022 or EN 50-035 din rails. The DIN rail mounts are attached to the same holes used for direct panel mounting.

NOTE: Do not operate the CAN Bridge without the antenna attached. Operating the CAN Bridge without the antenna attached could result in damage to the CAN Bridge radio circuitry.

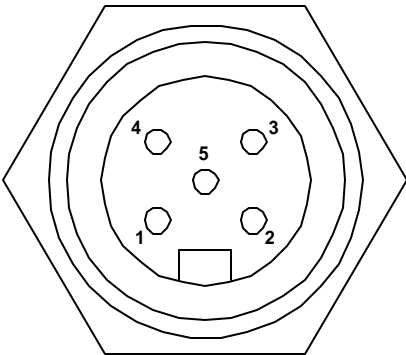

The Wireless CAN Bridge provides a sealed micro style connector that complies with the physical standards for DeviceNet* connectors. The CB-300 requires a tap to interface into the DeviceNet* trunk line. The pinout for the connector is shown at left.

Male (pins)

- 1 - Drain (bare)**
- 2 - V+ (red)**
- 3 - V- (black)**
- 4 - CAN_H (white)**
- 5 - CAN_L (blue)**

The three external antenna kits listed below are approved for use with the CAN Bridge. These antenna kits can be used to optimize the RF line of sight while locating the CAN Bridge unit for convenient wiring. Each antenna kit includes a 4.5 inch diameter ground plane, a 5/8 inch base mount, a 2.4 GHz antenna, and a cable in one of three lengths. The kits do not include a mounting bracket or clamps.

When properly installed, the base mount and antenna provide an IP67 seal. The cable is heavy duty, UV and weather resistant, low loss cable that has a maximum bending radius of 1 inch. Note: To ensure a proper seal, the O-Ring must be installed under the brass mount and the gasket inside the antenna must seal against the brass mount.

Description	Part Number
30 foot cable with 2.4 GHz antenna kit	186-0058
6 foot cable with 2.4 GHz antenna kit	186-0057
3 foot cable with 2.4 GHz antenna kit	186-0056

For optimal performance, the antenna for the CAN Bridge antenna should be mounted vertically and away from solid objects.

NOTE: The shielding in the remote antenna cable is attached to the connectors on both ends of the cable. Care should be taken to isolate the shielding of the antenna cable from the shielding of the DeviceNet cable to avoid ground loop problems. This can be accomplished by mounting the remote antenna to a non-conductive plate.

See the following diagrams for mounting dimensions and assembly instructions.

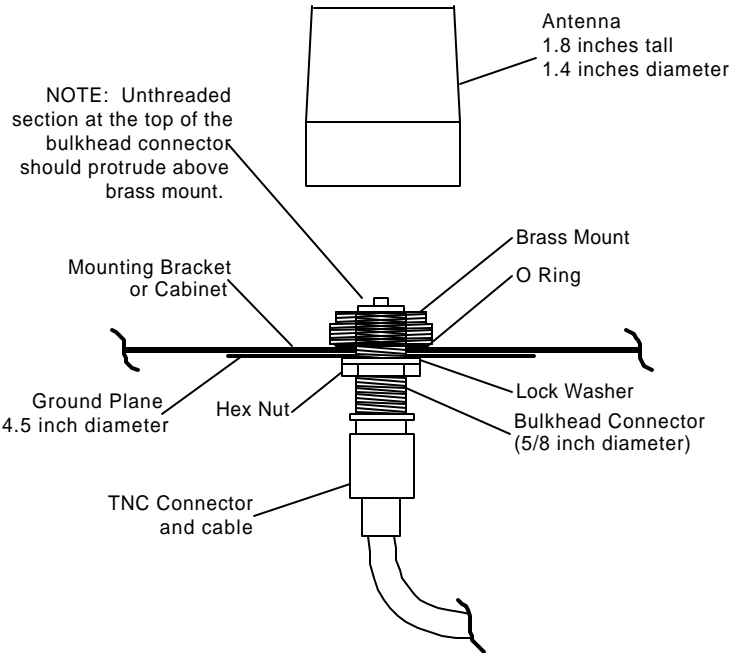
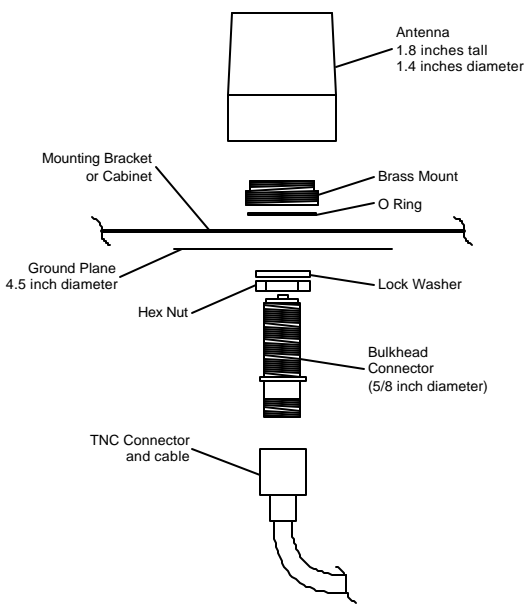

Spread spectrum systems located in the same general area can lead to signal contention which is known as a Near / Far problem. The interfering signals may be generated by the transmissions from one system (Link 2) which is located close to the receiver of a different system (Link 1) as shown in the second diagram. The interference generated by the two "near" radios could totally block communication between the proper radio pair. To avoid this situation it may be necessary to relocate the radios as shown in the first diagram.

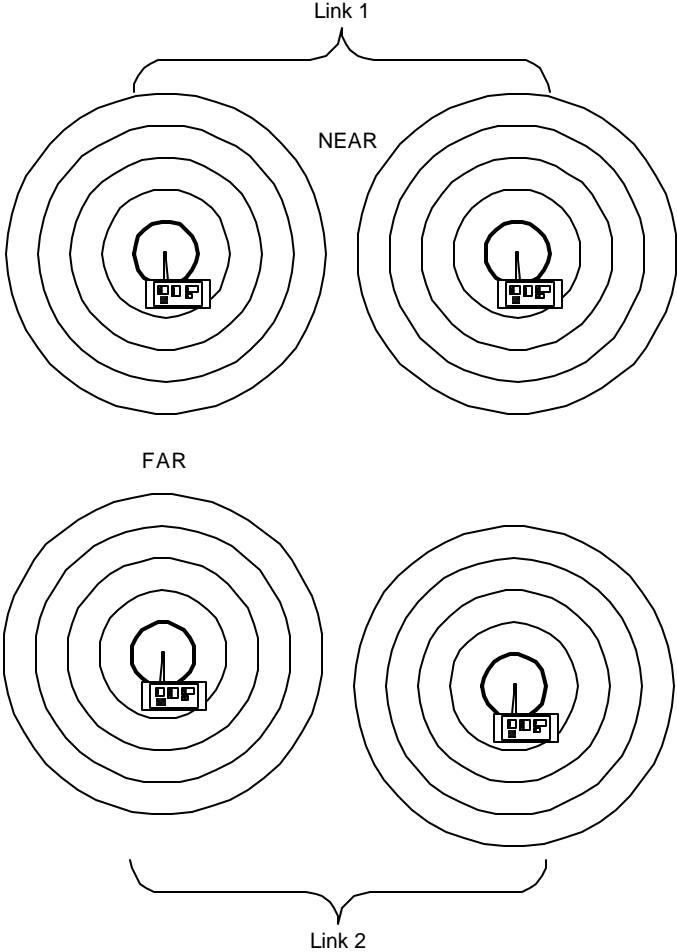

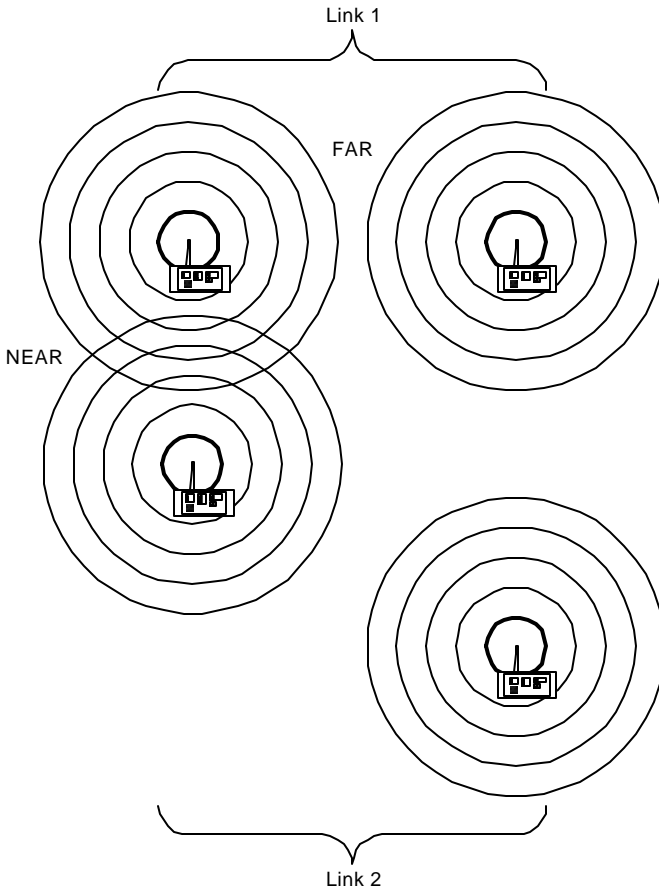

A site assessment should be performed before any new radio system is introduced into an operating environment. A thorough site assessment of an area will discover active radio frequencies that could lead to contention and their sources.

For optimal performance, the antenna for the Wireless CAN Bridge should be mounted vertically and away from solid objects. The Wireless CAN Bridge signal indicators can be used to identify the optimal antenna location without using complex radio equipment.

THEORY OF OPERATION:

The Wireless CAN Bridge involves three basic components. The first component is a CAN Interface that receives and transmits CAN frames on a trunk line in accordance with the Bosch 2.0b protocol. The Processor translates the CAN messages to/from data blocks that can be transmitted across the wireless link. Finally, a radio module reliably passes the packetized CAN messages between the CAN Bridge units.

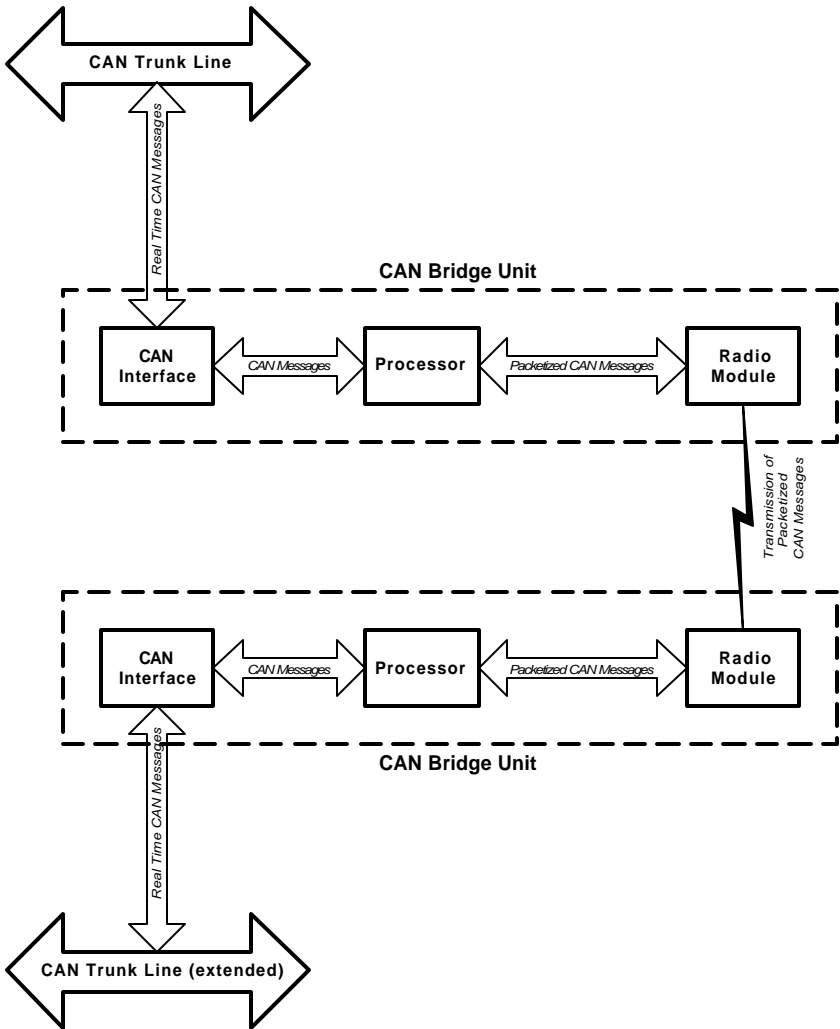

The CAN Bridge operates at the media level of a CAN system. CAN frames are created by higher level protocols and are transmitted on the CAN trunk line. The CAN Bridge passes the CAN frames across the wireless link without interpreting or reacting to the content of the frames. In this regard, the CAN Bridge functions as a “virtual trunk line”.

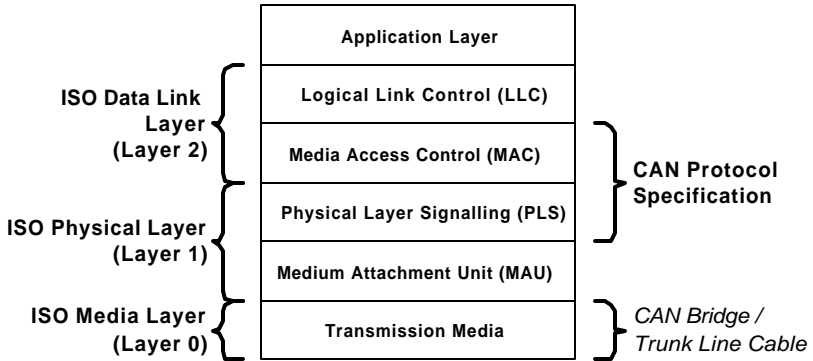

APPROVALS:

The Wireless CAN Bridge has been tested and found to comply with the limits for an intentional radiating device, pursuant to Part 15 of the United States FCC Rules. Changes or modifications not expressly approved by Matric could void the user's authority to operate the Wireless CAN Bridge.

The Wireless CAN Bridge has been tested and found to comply with European Community EMC Emissions and Immunity requirements (EN 300 328 and EN 301 489 01). Changes or modifications not expressly approved by Matric could void the user's authority to operate the Wireless CAN Bridge.

Operation is subject to the following two conditions:

- (1) this device may not cause interference, and
- (2) this device must accept any interference, including interference that may cause undesired operation of the device.



Matric

2099 Hill City Road
Seneca, PA 16346
814-677-0716
www.matric.com

Document Number: 185-0042
Manual Wireless CAN Bridge v9.pub
*DeviceNet is a registered trademark of ODVA
Copyright 2000, Matric
Printed in USA, 4/10/02