

Technical Manual

Wireless CAN Bridge 500 (CB-500)



DESCRIPTION:

The Wireless CAN Bridge functions as a wireless link that transfers CAN messages. Using the Wireless CAN Bridge, nodes on either side of a wireless link can communicate at a separation of up to 200 feet. A full 64 node DeviceNet* can be implemented depending on scan rates and frame density. Since actual CAN messages are transferred, the Wireless CAN Bridge supports any type of CAN bus standard including CAN Open and CAN Kingdom.

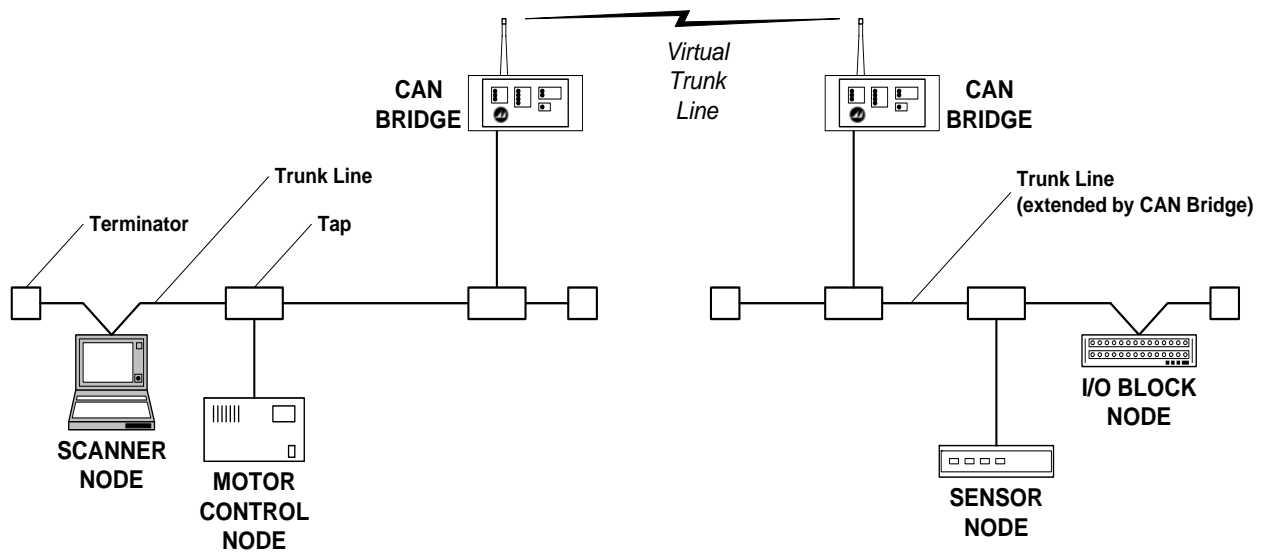



SPECIFICATIONS:

Functional

- 1200 frames per second transfer rate (max)
- Supports any CAN Bus or DeviceNet* (Bosch CAN 2.0b)
- Five pin male micro connector
- 16 bit CPU
- CPU watchdog

Radio

- Typical range of 200 feet with unobstructed line of sight
- 2.4 – 2.4835 GHz with 16 channels
- FSK modulation
- Output power, .003 mW
- Single heterodyne conversion
- Radio complies with FCC Part 15B, no user license required

Configuration Options

- Configuration via internal dip switches
- Radio link master or slave
- Standard versus extended CAN frame formats
- Host Interface baud rate (125K, 250K, 500K)
- Channel (1-16)
- Radio retry level

Power Source

- Requires SELV power supply at connector "Network".
- See installation section for wiring information.
- 7-30VDC, 200 mA at 24VDC +/- 5%

Status Indicators

- Signal strength
- Bus loading
- Data Loss Cause
- Power

Physical

- Size: 3 1/8 X 3 X 6 5/16 Inches
- Weight: 1 Lb
- DIN rail or panel mount
- Sealed enclosure
- Operational temperature 0°C to 70°C
- Storage temperature -40°C to 85°C



APPLICATION:

The Wireless CAN Bridge provides a frame transfer rate of 1200 CAN frames per second which is roughly equivalent to a fully loaded 125k baud system. The effectiveness of the CAN Bridge in any particular application depends on network loading. The loading on a CAN based network is affected by a number of factors including: polling rate of the network scanner, node count, change-of-state activity, and device power up behavior. According to ODVA, 30% loading is recommended for DeviceNet systems employing change-of-state devices and 80% loading is recommended for polled DeviceNet systems. Heavily loaded systems increase the probability that CAN messages will be discarded due to RF bandwidth limitations.

The transfer rate of 1200 fps is based on a typical scenario of less than 200 feet separation without significant RF obstacles. The actual transfer rate in any application is dependent upon the quality of the RF link. Structural components such as steel walls or decking, earth tunnels, and metal equipment can affect the quality of the RF link. Also, radiation sources such as other radio systems, high power switching, and magnetic fields can affect the quality of the RF link. A site assessment should be performed at any site where a new RF control is to be installed.

The Wireless CAN Bridge provides a point-to-point data transfer in order to achieve the required throughput over the wireless link. A system requiring multiple wireless links can accomplish this using multiple pairs of the Wireless CAN Bridge.

The rate at which CAN frames are received and transmitted by the Wireless CAN Bridge falls within the timing constraints of Bosch CAN Standard 2.0b. While meeting network requirements for data link and higher levels of communication, the time required for retransmission may still have an effect on the overall timing of a control system.



CONFIGURATION:

Configuration of the Wireless CAN Bridge is accomplished by manually setting switches inside its enclosure. The CAN Bridge enclosure lid must be removed to access the configuration switches. Users may only perform the configuration described in this manual. Changing other switch or trimmer settings may invalidate agency approvals.

To access configuration switches, first, use a flat screwdriver to pry off the two decorative covers at the right and left ends of the lid. Four pry slots are provided as shown below. Then unscrew the four screws that attach the lid to the chassis of the Wireless CAN Bridge using a philips or a flat screwdriver.

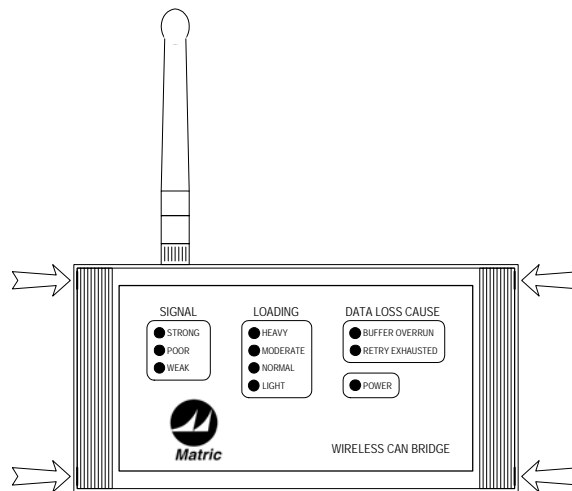

The Wireless CAN Bridge has 12 configuration switches arranged in 2 banks S1 and S2. Each bank contains 6 switches. These switches allow the user to easily customize the Wireless CAN Bridge to fit the desired application.

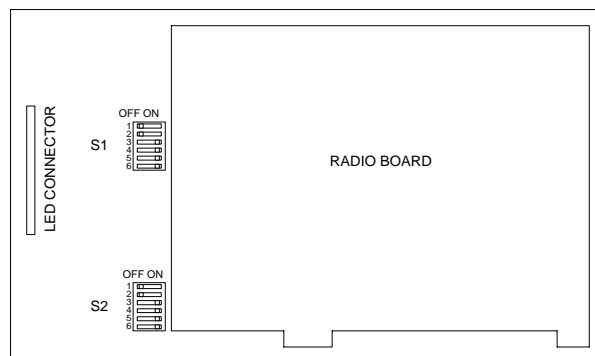



IMPORTANT: Employ ESD precautions to avoid static discharge when touching the CAN Bridge circuit board. ESD can cause damage leading to catastrophic or intermittent product failure modes.

The following paragraphs describe each switch setting in more detail. The format Sb:s, where b is the bank number and s is the switch number within that bank, will be used. The “as shipped” settings are shown with an asterisk “*”.

The CB-500 must be reset (power cycled) before switch settings take effect.

Switch S1:1 Selects Node Communication Type for internal radios. A Radio System must consist of only one Server (master) and only one Client (slave) per channel. The Server is the initiator of the radio pair. Before the radios link, the Client will only listen for a Server and the Server will transmit to find a Client.

Radio Operation	S1:1
Server	ON
Client	OFF*

Switch S1:2 Reserved. Should be in the OFF* position.

Switches S1:3,4,5,6 Selects the operating channel. A master/slave pair must be set to the same channel to operate properly.

Channel	S1:3	S1:4	S1:5	S1:6	Freq (GHz)
1*	OFF*	OFF*	OFF*	OFF*	2.405*
2	OFF	OFF	OFF	ON	2.410
3	OFF	OFF	ON	OFF	2.415
4	OFF	OFF	ON	ON	2.420
5	OFF	ON	OFF	OFF	2.425
6	OFF	ON	OFF	ON	2.430
7	OFF	ON	ON	OFF	2.435
8	OFF	ON	ON	ON	2.440
9	ON	OFF	OFF	OFF	2.445
10	ON	OFF	OFF	ON	2.450
11	ON	OFF	ON	OFF	2.455
12	ON	OFF	ON	ON	2.460
13	ON	ON	OFF	OFF	2.465
14	ON	ON	OFF	ON	2.470
15	ON	ON	ON	OFF	2.475
16	ON	ON	ON	ON	2.480



Switches S2:1,2 Selects the bit rate of the CAN or DeviceNet network.

Bit Rate (Bits/Sec.)	S2:1	S2:2
125K	ON	ON
250K	OFF	ON
500K	ON	OFF
125K	OFF	OFF

Switches S2:3 Selects Standard or Extended CAN framing. DeviceNet* uses standard framing. Some varieties of CAN may use extended framing.

CAN Type	S2:3
11 bit (Standard CAN)	ON
29 bit (Extended CAN)	OFF

Switches S2:4 Enables frequency agile mode. Units will hop to a clear channel if errors are encountered (retry count exceeded). Note: Both units must have this enabled for the feature to work properly.

Frequency Agile	S2:4
Enabled	ON
Disabled *	OFF *

Switches S2: 5,6 Selects the number of retries. The radio will retransmit an unsuccessful packet the selected number of times before discarding the packet. Increasing retries may slow the communication process, but may help reduce discarded packets.

Retries	S2:5	S2:6
1	ON	ON
16 *	ON *	OFF *
64	OFF	ON
128	OFF	OFF



INDICATORS:

The Wireless CAN Bridge provides three separate groups of diagnostic LED indicators. The groups are labeled "Signal", "Loading", and "Data Loss Cause." In addition to these groups, a power indication LED is also provided.

Signal Indicators The signal indicators provide information about the integrity and robustness of the RF Signal. The three levels may be described as a function of data throughput.

Strong	Indicates the best data throughput. Data packets are being transferred to the radio at a rate equivalent to between 100% and 110% of full CAN trunk line loading (at 125k baud).
Poor	Reduced data throughput. Data packets are being transferred at a rate between 50% and 100% loading at 125k baud.
Weak	Radios are linked, but data throughput is low. Data packets are being transferred at a rate between 0% to 50% loading.
No Indicators	Data rate is zero. No RF link established.

Data Loss Cause The data loss cause indicators provide information about packets that are discarded due to throughput constraints. Two indications are provided, Buffer Overrun and Retry Exhausted. Scanner retries must be set at a level that mitigates data loss at the system level.

Buffer Overrun	CAN packets entering the transmit buffer have overrun the RF link capacity. One or more CAN messages are discarded.
Retry Exhausted	The configured number of RF transmit retries has been exceeded. One or more RF packets are discarded. Note: RF data packets may contain up to 2 CAN messages.
No Indicators	No data loss.



Loading Indicators The loading indicators show the number of CAN packets that are being written to the RF transmit buffer. The four levels may be described as a function of RF bandwidth usage by CAN packets. Note: Buffer overruns may affect this indicator due to discarded CAN packets.

Heavy	50 % - 100 % of the available bandwidth is being utilized for CAN messages.
Moderate	35 % - <50 % of the available bandwidth is being utilized for CAN messages.
Normal	10 % - <35 % of the available bandwidth is being utilized for CAN messages.
Light	0 ⁺ % - <10 % of the available bandwidth is being utilized for CAN messages.
No Indicators	No CAN messages transferred.

Power Indicator The power indicator implies the presence of electrical power. It is a hardwired LED that does not indicate the quality of the power detected.

Power LED On	DC Power is On.
No Illumination	DC Power is Off.



INSTALLATION:

The Wireless CAN Bridge can be bolted directly to a control panel, or mounted to a DIN rail. Remove the two decorative covers at the right and left ends of the lid to access the mounting holes for direct panel mount (or to attach the DIN rail clips). See the Configuration section for instruction on removing the decorative covers.

Use adequate material and fasteners when panel mounting the CAN Bridge unit with consideration to any vibration or shock the unit may experience. Suggested specifications are listed below.

Panel	Fastener
1/2 inch plywood	5/8 x #8 wood screw
1/8 inch aluminum	10-32 machine screw to threaded hole or bolt
1/2 inch plaster board	Wall anchor with #6 machine screw

CAUTION: Many types of threadlock will weaken the plastic enclosure of the CAN Bridge. Instead, use lock washers, or a threadlock that will not damage plastic (such as Premabond MM115) to secure mounting screws. Do not over-torque panel mounting screws. Use washers between the CAN Bridge and panel to protect the enclosure and provide a solid base for tightening mounting screws.

A DIN rail mounting kit is included for attaching the Wireless CAN Bridge to either EN 50-022 or EN 50-035 DIN rails. The DIN rail mounts are attached to the same holes used for panel mounting.



The Wireless CAN Bridge provides a sealed micro style connector (labeled “Network”) that complies with the physical standards for DeviceNet* connectors. The CB-500 requires a tap to interface into the DeviceNet* trunk line. The pinout for the connector is shown below. Note: The CAN Bridge 500 requires a SELV power supply with power output intrinsically limited to under 8 amps at a maximum of 30VDC. If a protective device is used with a power supply that exceeds this requirement it must be rated to trip at a current equal to 1000/Vin. Protective devices must be fuses or breakers and must be non-adjustable, nonautoreset, electromechanical devices.

Network
Male (pins)

- 1 – Drain (bare)
- 2 – V+ (red)
- 3 – V- (black)
- 4 – CAN_H (white)
- 5 – CAN_L (blue)

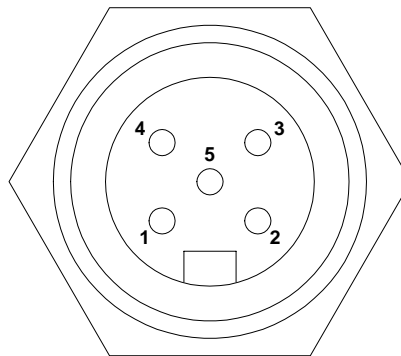

The Wireless CAN Bridge provides factory test functions via a sealed micro style connector (labeled “Auxiliary”). This connector is not used during normal operation.

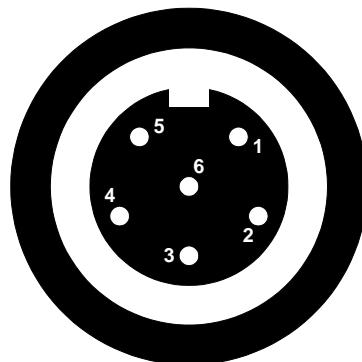



APPROVALS:

The Wireless CAN Bridge has been tested and found to comply with the limits for a Class A digital device, pursuant to Part 15 of the FCC Rules. These limits are designed to provide reasonable protection against harmful interference when the equipment is operated in a commercial environment. The Wireless CAN Bridge generates, uses, and can radiate radio frequency energy and, if not installed and used in accordance with the instruction manual, may cause interference to radio communications and harmful microwave emissions. To limit exposure radio frequency radiation, the CAN Bridge should be installed and operated with a minimum distance of 20 centimeters between the antenna and all persons and must not be collocated or operating in conjunction with any other antenna or transmitter.

Operation of this equipment in a residential environment is likely to cause harmful interference to other residential devices in which case the user will be required to correct the interference at their own expense. Changes or modifications not expressly approved by Matric could void the user's authority to operate the Wireless CAN Bridge.

The Wireless CAN Bridge has been tested and found to comply with European Community EMC Emissions and Immunity requirements (EN 300 328 and EN 301 489 01).

Operation is subject to the following two conditions:

- (1) this device may not cause interference, and
- (2) this device must accept any interference, including interference that may cause undesired operation of the device.

The Wireless CAN Bridge has been designed to operate with the antenna listed below, and having a maximum gain of 1 dB. Antennas not included in this list or having a gain greater than 1 dB are strictly prohibited for use with this device. The required antenna impedance is 50 ohms.

Approved Antennas		
Manufacturer	Part Number	Description
Centurion	WCR2400SMRP	½ wave coaxial dipole



For technical support, contact:

Matric
2099 Hill City Road
Seneca, PA 16346

(814) 677-0716

www.matric.com